

# Effect of grinding conditions on the fatigue life of titanium 5Al–2.5Sn alloy

P. RANGASWAMY, H. TERUTUNG, S. JEELANI

*Materials Research Laboratory, School of Engineering and Architecture, Tuskegee University, Tuskegee, AL 36088, USA*

The principal factors in the performance of aerospace materials are strength-to-weight ratio, fatigue life, fracture toughness, survivability and of course reliability. Machining processes, and in particular grinding under adverse conditions, have been found to cause damage to surface integrity and affect the residual stresses distribution in the surface and sub-surface region. These effects have a direct bearing on the fatigue life. In this investigation the effect of grinding conditions on the fatigue life of titanium 5Al–2.5Sn was studied. This alloy is used in ground form in the manufacturing of some critical components in the space shuttle's main engine. It is essential that materials for such applications be properly characterized for use in severe service conditions. Flat sub-size specimens 0.1 in. (2.5 mm) thick were ground on a surface grinding machine equipped with a variable-speed motor at speeds of 2000 to 6000 fpm (10 to 30  $\text{m sec}^{-1}$ ) using SiC wheels of grit sizes 60 and 120. The grinding parameters used in this investigation were chosen from a separate study. The ground specimens were then fatigued at a selected stress and the resulting lives were compared with that of the virgin material. The surfaces of the specimens were examined under a scanning electron microscope and the roughness and hardness were measured using a standard profilometer and microhardness tester, respectively. The fatigue life of the ground specimens was found to decrease with an increase in speed for both dry and wet conditions. For both the grit sizes, the fatigue life was lower than that of the virgin material for the dry condition. The fatigue life of specimens ground under wet conditions showed a significant increase at the wheel speed of 2000 fpm (10  $\text{m sec}^{-1}$ ) for both grit sizes, and thereafter decreased with increase in speed to below that of the virgin material. The results of the investigation are explained using profilometry, microhardness measurements and scanning electron microscopic examination.

## 1. Introduction

Titanium alloys are extensively used in aerospace applications because they meet the design and service requirements. It is observed that during manufacturing the consistent preservation of their inherent strength is difficult to achieve. Catastrophic failures have resulted from damage to the surface integrity by machining during manufacturing. Therefore, manufacturing procedures are required to be specified to avoid damage to the surface and the sub-surface, and, if possible, to specify processing which will enhance part performance. This makes it imperative for the design engineer to possess complete information about the surface characteristics of a component and the mechanical properties of the bulk material before the component is designed, so that manufacturing procedures can be suggested to withstand service conditions such as fatigue, creep and stress corrosion cracking [1–3]. Previous investigations have shown that in the machining of metals a damaged surface region is produced that is different from the bulk of the material [4–7]. Changes in material surface properties can, in turn, influence mechanical properties of which

fatigue life and stress corrosion resistance are usually of the most concern [8–11].

Of the various material removal processes studied to date, grinding causes the most impact on material properties [12, 13]. Grinding is an abrasive machining process (more precisely termed a micro-machining process), and it differs from machining in that grinding speeds are much faster, the depth of cut smaller, and there is very little quantitative information on the geometry of individual grits at the periphery of grinding wheels. Studies on surface alterations due to grinding have revealed that the extent of the deformed layer depends on the size of the grit as well as its rake angle, grinding speed and depth of cut [14]. Studies carried out on grinding of titanium and titanium alloys (Ti–6Al–4V) have also revealed that a large-scale redeposition of metal on the surface accounts for poor surface finish at high speeds using silicon carbide (SiC) and aluminium oxide ( $\text{Al}_2\text{O}_3$ ) grinding wheels [15]. Also, the high temperatures developed at the wheel–work interface due to the vast range of process parameters involving rapid rates of material removal has led to lowering the level of surface integrity and

producing an extremely complex pattern of residual stress distribution [8, 12]. These factors have a detrimental effect on the fatigue strength and fatigue life of the components.

The objective of this research was to investigate the effects of grinding on the fatigue life of Ti-5Al-2.5Sn at room temperature under dry and wet conditions. There are no data available for the test range considered in this work to show what effect, if any, grinding has on the fatigue life of Ti-5Al-2.5Sn alloy at various grinding speeds and for various grit sizes.

## 2. Experimental procedure

### 2.1. Specimen preparation

The Ti-5Al-2.5Sn alloy used in this investigation is an alpha-type alloy and is the most widely used commercial alloy in this group. It exhibits excellent fracture toughness and corrosive resistance and is widely used for structural and cryogenics applications. Mechanical properties and chemical composition of the material are given in Tables I and II, respectively.

The sub-sized specimen and the loading grips used in this investigation to hold it were selected from the work done earlier by Jeelani *et al.* [16]. The specimen was designed with 0.1 in. (2.5 mm) gauge section width and 1.0 in. (25 mm) gauge section length. The specimen thickness was 0.1 in. The specimen was made according to the specification shown in Fig. 1, on a numerically controlled machining centre. The specimen was made out of a 2 in. (50 mm) long flat plate, 0.75 in. (19 mm) wide and 0.125 in. (3 mm) in thickness.

After the specimens were fabricated, they were annealed by heating and holding at 1400 °F (760 °C) for 60 min and at 1600 °F (871 °C) for 10 min and then cooling in air. Stress relieving was performed by soaking the specimens for 1 h at 1000 °F (538 °C). However, it should be noted that Ti-5Al-2.5Sn cannot be hardened by heat treatment. It is used only in the annealed condition [17].

The oxidized layer and the toolmarks and other surface irregularities were removed by wet grinding/polishing using silicon carbide emery papers of sizes

TABLE I Mechanical and physical properties of titanium 5Al-2.5Sn

Ultimate tensile strength	120 ksi (827 MPa)
Yield strength (0.2 % offset)	115 ksi (793 MPa)
Hardness (Rockwell C)	36 Rc
Elongation in 2 in. (51 mm)	10%
Reduction of area	25%
Impact, Charpy V	19 ft.lb (84.5 N)
Rupture stress	108 ksi (745 MPa)
Modulus of elasticity, tension	16 Mpsi (110 GPa)
Modulus of elasticity, torsion	6.5 Mpsi (45 GPa)
Density	0.162 lb/cu in. (4484 kg m <sup>-3</sup> )
Melting range	2822 to 3000 °F (1550 to 1649 °C)
Specific electrical resistance	157 × 10 <sup>-6</sup> Ω cm
Specific heat	0.125 Btu/lb <sup>o</sup> F (0.523 J g <sup>-1</sup> °C <sup>-1</sup> )
Mean coefficient of thermal expansion	5.2 × 10 <sup>-6</sup> °F <sup>-1</sup> (9.4 × 10 <sup>-6</sup> °C <sup>-1</sup> )

TABLE II Chemical composition

Element	Content (wt %)
Al	4.0 to 6.0
C	0.15
H	0.003 to 0.020
Fe	0.5
Mn	0.3
N	0.07
O	0.2
Sn	2.0 to 3.0
Ti	Balance

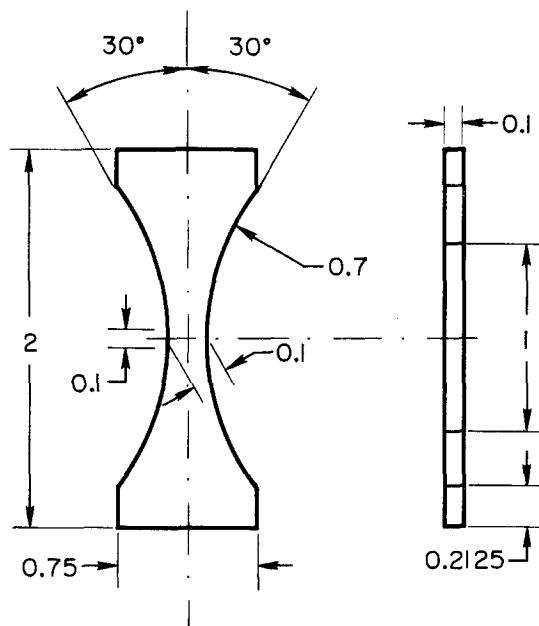

Figure 1 Fatigue specimen. All dimensions in inches (1 in. = 25.4 mm).

ranging from 60 to 4000 grits per square inch (9 to 620 cm<sup>-2</sup>).

### 2.2. Grinding tests

The grinding of all the specimens was carried on a precision surface grinding machine (Boyar-Schultz 1A618 Hydraulic Surface Grinder), equipped with a 2 hp (1490 W) variable-speed motor (0 to 6000 r.p.m.) powered by Volkman Drives 2 HP Adjustable drive unit which converts the fixed-input a.c. frequency to the motor to a variable-frequency range, thus changing the usually fixed motor speed to a variable speed.

Grinding was carried out with silicon carbide (39C60H8VK and 39C120I8VK) wheels. The wheels were of 6 in. (152 mm) diameter and 0.5 in. (13 mm) width received in dressed condition (coarse dressing). Grinding wheel speeds of 2000–4000–6000 fpm (10–20–30 m sec<sup>-1</sup>) were used and a table speed of 40 fpm (0.2 m sec<sup>-1</sup>). All grinding tests were made in a single pass. Table III shows a summary of the grinding conditions used in this investigation. These conditions are based on the Metcut recommendations [12].

### 2.3. Fatigue testing

For testing the virgin and the ground specimens a direct tension-compression fatigue testing machine

TABLE III Summary of grinding conditions

Wheel type	39C60H8VK, 39C120I8VK
Wheel speed (fpm)	2000, 4000, 6000 (10, 20, 30 m sec <sup>-1</sup> )
Table speed (fpm)	50
Down feed per pass	0.0005 in. (13 μm) (16 passes) <sup>a</sup> 0.0004 in. (10 μm) (2 passes) 0.0002 in. (5 μm) (6 passes) <sup>b</sup>
Cross feed (in./pass)	0.05
Wheel classification	Soft grade (H, I) Open structure (8) Grain size (60, 12)

<sup>a</sup> All grinding done in single pass.

<sup>b</sup> Wheel dressed before final pass (coarse dressing done to maintain sharpness).

(Fatigue Dynamics model DS-6000 HLM) equipped with a hydraulic load maintainer was used. It adjusts the preload continuously to a preset value without affecting the cyclical load. The cyclical load can be adjusted manually up to 6000 lb (2720 kg). The test frequency of the machine ranges from 600 to 2200 cycles min<sup>-1</sup>. A load cell is provided to read tensile or compressive load on the specimen, directly. The load cell is connected to the strain indicator which is calibrated to read the load on the specimen. A stress ratio of  $R = 0$  was used in this investigation. Throughout the test, the cycle speed was maintained constant at 200 cycles min<sup>-1</sup>. Tests were performed at room temperature.

#### 2.4. Surface examination

Small pieces approximately 0.25 in. × 0.25 in. (6 mm × 6 mm) were cut from all virgin and ground specimens. The pieces were cleaned in an aqueous methanol solution, and were then air-dried. The ground surfaces were examined in a scanning electron microscope over a wide range of magnification.

A Bendix profilometer group 7L equipped with a Sheffield profilometer model QED-6, digital amplifier, Sheffield profilometer type VEG Gated Pilator and type LK tracer with Ft skid-mount was used to measure the roughness of the surfaces produced. A tracer stroke of 0.5 in. (13 mm) was used with a selected cut-off of 0.0125 in. (0.3 mm). The roughness measurements were made on the specimens in the direction parallel to the work-tool motion. Surface roughness measurements of the parent metal specimens as well as those of the specimens ground were taken.

Microhardness measurements using a Buhler Micromet II digital microhardness tester were made on the ground surfaces produced at all wheel peripheral speeds. At least five measurements were made on each specimen and the average taken for comparison.

### 3. Results and discussion

Fig. 2 shows the S-N diagram generated by using 30 polished specimens of Ti-5Al-2.5Sn alloy. Approximately five specimens were tested at each stress level and the fatigue life data were obtained at five stress levels.

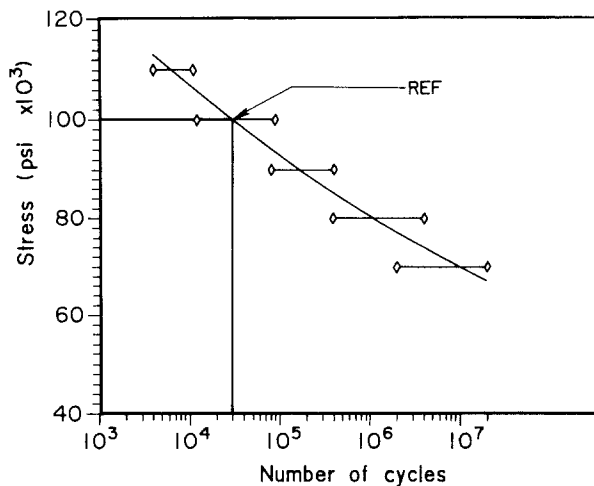

Figure 2 S-N diagram for titanium 5Al-2.5Sn alloy virgin material. 1000 psi = 6.895 MPa.

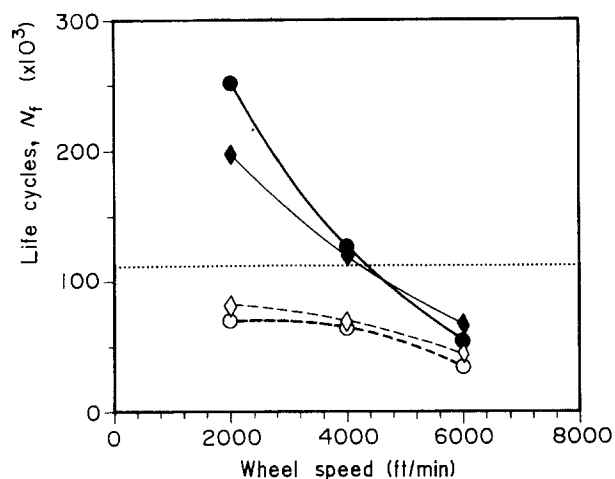

Figure 3 Fatigue life against wheel speed: virgin material and ground specimens. (○) Dry ground 60, (●) wet ground 60, (◇) dry ground 120, (◆) wet ground 120, (⋯) virgin. Selected stress level =  $10^5$  psi (690 MPa). 1000 ft/min = 5 m sec<sup>-1</sup>.

A software called Grapher especially used for producing two-dimensional graphs was used to produce the S-N curve. Point REF in the diagram, which corresponds to a stress of 100 000 psi (690 MPa) and the fatigue life of 125 000 cycles was used as a reference for comparison of the lives of the specimens ground under various conditions used in this investigation.

Fig. 3 shows the effect of the type and speed of the grinding wheel and the presence or absence of the cutting fluid on the fatigue life of the specimens. Each data point on the graph represents an average of five tests. For the specimen ground with wheels of both grit sizes (60 and 120) the fatigue life decreases with an increase in the speed. This trend is consistent with the data published by previous workers [8, 18, 19]. The fatigue life of the specimens ground under dry conditions was lower than that of the virgin specimens. Dry grinding is also termed "abusive grinding" which is shown to cause severe damage to the surface integrity and affect the residual distribution at the surface, which lowers the fatigue strength and therefore results in lowering the fatigue life. Published data have indicated that dry grinding generally produces tensile stress

near to the surface under conditions far from low stress condition [7, 20, 21].

Fig. 4 shows the variation in the surface roughness due to a change in the type and speed of the grinding wheel and the presence or absence of the cutting fluid. It can be seen that for all the grinding conditions used in this investigation the surface roughness is higher than that of the virgin material, and increases as the grinding speed is increased. The presence of cutting fluid in the grinding region has decreased the surface roughness, but the change does not appear to be significant. The graph shows that the surface roughness changes with a change in the grit size of the grinding wheel, but the change is not significant enough to establish a trend.

Fig. 5 shows the variation in the microhardness due to a change in the type and speed of the grinding wheel and the presence or absence of the cutting fluid. For all the grinding conditions used in this investigation it can be seen that the microhardness values show a decrease in hardness with an increase in grinding speed. The presence of cutting fluid slightly increases the hardness values of the specimens ground under wet conditions as compared with the specimens ground dry. At the low grinding speed of 2000 fpm ( $10 \text{ m sec}^{-1}$ ) the hardness of the specimens ground under wet conditions is higher than that of specimens ground dry. This trend is consistent upto 4000 fpm ( $20 \text{ m sec}^{-1}$ ) but thereafter it is observed that with an increase in the grinding speed the specimens ground with the wheel of grit size 120 for both the dry and wet conditions show slightly higher hardness values than those of the specimens ground with the wheel of 60 grit size. Here again, the graph shows that the microhardness changes due to a change in the grit size of the grinding wheel, but again, the change is not significant enough to establish a trend.

The scanning electron micrographs of the surfaces produced under both dry and wet conditions showed that the surfaces consisted of microcracks and tears showing ploughing of the metal by the abrasive action

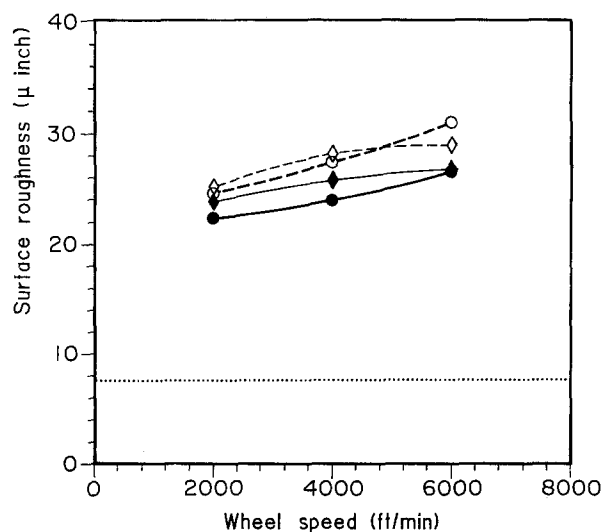

Figure 4 Surface roughness against wheel speed: virgin material and ground specimens. (○) Dry ground 60, (●) wet ground 60, (◇) dry ground 120, (◆) wet ground 120, (⋯) virgin. 1000 ft/min =  $5 \text{ m sec}^{-1}$ ;  $1 \mu \text{ inch} = 25.4 \text{ nm}$ .

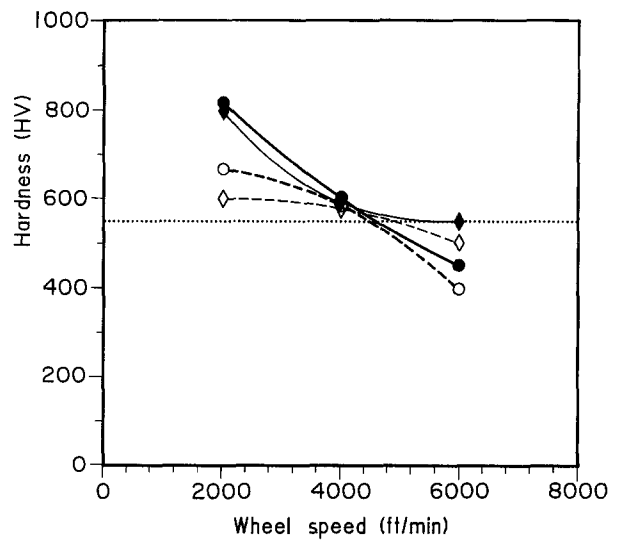

Figure 5 Vickers hardness against wheel speed: virgin material and ground specimens. (○) Dry ground 60, (●) wet ground 60, (◇) dry ground 120, (◆) wet ground 120, (⋯) virgin. 1000 ft/min =  $5 \text{ m sec}^{-1}$ .

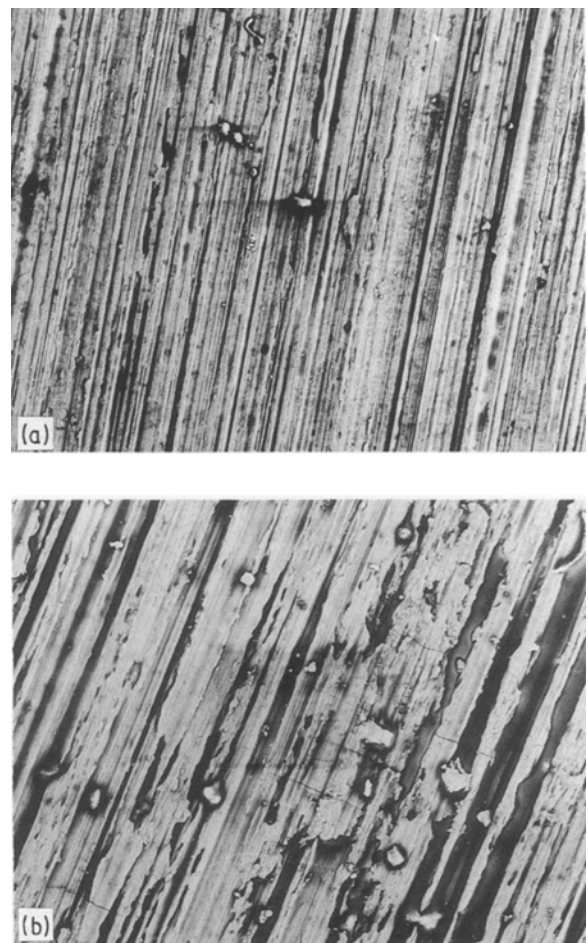

Figure 6 Scanning electron micrographs of surfaces ground under dry conditions: (a) magnification  $\times 150$ , grinding speed 2000 fpm ( $10 \text{ m sec}^{-1}$ ); (b) magnification  $\times 150$ , grinding speed 6000 fpm ( $30 \text{ m sec}^{-1}$ ).

of the grit, evidence of large-scale plastic deformation, redeposition and cavities. The texture showed grooves of non-uniform width and spacing for all the grinding speeds [22, 23].

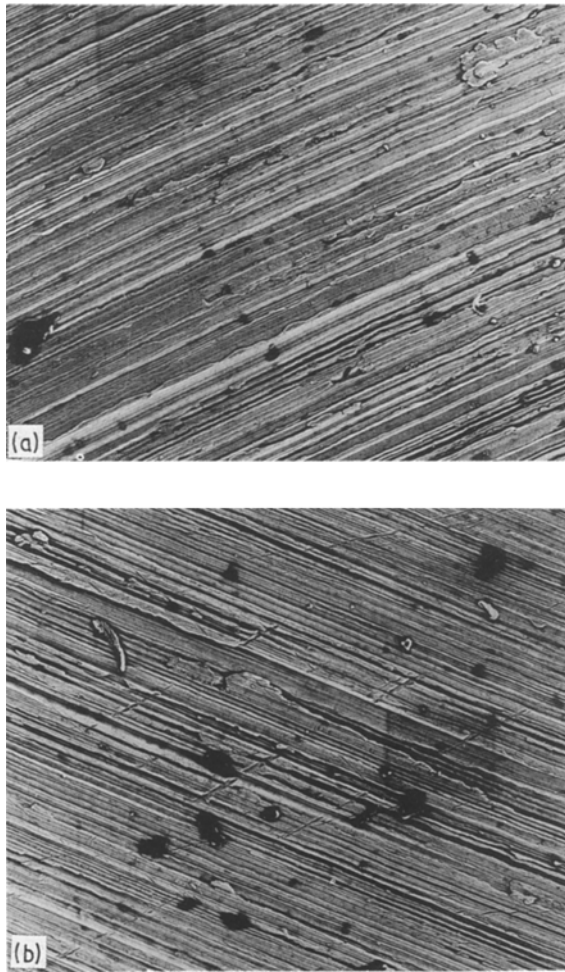

Figure 7 Scanning electron micrographs of surfaces ground under wet conditions: (a) magnification  $\times 150$ , grinding speed 2000 fpm ( $10 \text{ m sec}^{-1}$ ); (b) magnification  $\times 150$ , grinding speed 6000 fpm ( $30 \text{ m sec}^{-1}$ ).

Fig. 6a and b show scanning electron photomicrographs of the surfaces produced when ground under dry conditions with the wheel of 60 grit size at the lowest and highest grinding speed in the range tested. These photomicrographs reveal a drastic change in texture ranging from long straight grooves parallel to the wheel-work direction to short discontinuous grooves which vary in width and depth with an increase in the grinding speed. This also explains the high roughness values obtained with increase in speed. It was also observed, that at a speed of 6000 fpm ( $30 \text{ m sec}^{-1}$ ) the ground surfaces revealed cracks and microcracks for both the grit sizes. The cracking occurs because of the generation of heat during the transfer of metal (redeposition) back on to the ground surface at high speeds and subsequent rapid cooling. These cracks and microcracks could be one of the reasons for the decrease in fatigue life of the specimens ground under dry conditions at higher speeds. The effects of rubbing, ploughing and cutting, a characteristic of the grinding process, were present for all three speeds [12].

Fig. 7a and b show scanning electron photomicrographs of the surfaces produced when ground under wet conditions with the wheel of 60 grit size at the lowest and highest grinding speed in the range tested.

The texture was well defined at the low grinding speed of 2000 fpm ( $10 \text{ m sec}^{-1}$ ), indicating that a considerably lesser amount of redeposition on the surface had taken place. Also, the micrographs revealed that the extent of severity of damage caused to the surface was considerably less than for the surface ground under dry conditions. However, at the speed of 6000 fpm ( $30 \text{ m sec}^{-1}$ ) the surface did reveal cracks transverse to the direction of grinding similar to those on the surfaces ground under dry conditions, which resulted in a considerable decrease in fatigue life. This shows that the presence of cutting fluid, which has appreciably reduced the wheel-workpiece temperature and also aided in removing the grinding chips, thereby minimizing redeposition, has virtually no effect in preventing damage to the surface in the form of cracks as a result of the increase in process intensity caused by an increase in grinding speed.

Studies have shown that grinding carried out at low speeds in the presence of a lubricant results in producing residual stresses which are compressive in nature in the surface and the sub-surface region [12]. For the titanium alloy used in this investigation, there are no data reported yet concerning the nature of the residual stresses in the surface and sub-surface due to grinding.

The surface roughness measurements also show that the roughness increases with an increase in the grinding speed, an observation which is supported by the SEM photomicrographs shown in Figs 6 and 7. It is to be noted, as mentioned earlier, that this particular alloy cannot be hardened and therefore the high temperatures reached due to the heat generated at the work-wheel interface anneal the workpiece, thereby softening the workpiece at the surface and the sub-surface region. This is one of the reasons for the microhardness measurement showing a decrease with an increase in the grinding speed. Also, visual examination of the surface of the specimens ground under dry condition at high speeds showed evidence of burnt marks.

#### 4. Conclusion

From the results of the investigation of the effect of grinding conditions on the fatigue life of titanium 5Al-2.5Sn, the following conclusions may be drawn:

1. The results of the study indicated that fatigue life of the specimens decreased considerably with an increase in the speed. The fatigue life of the specimens ground under dry conditions was lower than that of the virgin specimens for the speed range tested. The fatigue life of the specimens ground with cutting fluid was higher than that of the virgin specimens in the speed range of 2000 to 4000 fpm ( $10$  to  $20 \text{ m sec}^{-1}$ ).

2. The results of surface roughness measurements over the entire speed range of the ground specimens showed an increase in roughness with an increase in the speed. The roughness values of the specimens ground under dry and wet conditions were higher than those of the virgin specimens. The roughness of the specimens ground under dry conditions was higher than that of the specimens ground under wet conditions at all speeds and for both the grit sizes.

3. The microhardness measurements for both the grit sizes and for both the dry and wet conditions used in this investigation showed a decreasing trend in hardness for all the speeds.

4. The grit size of the grinding wheel selected for this study showed no significant effect on the fatigue life.

### Acknowledgement

The authors gratefully acknowledge the support of NASA-Marshall Space Flight Center through Grant NAG8-068 for this study.

### References

1. K. RAMAKRISHNAN, MS thesis, Tuskegee Institute (1979).
2. W. P. KOSTER, M. FIELD, L. J. FRITZ, L. R. GATTO and J. F. KAHLES, "Surface Integrity of Machined Structural Components", USAF Technical Report AFML-TR-70-11 (Metcut Research Associates Inc., Cincinnati, Ohio, 1970).
3. W. P. KOSTER and M. FIELD, in Proceedings of North American Metalworking Research Conference, Hamilton, Ontario, May 1973, Vol. 2 (McMaster University, Hamilton, 1973) pp. 67-87.
4. J. A. BAILEY and S. JEELANI, *SME Trans.* (1974) 174.
5. *Idem*, *Wear* **36** (1976) 199.
6. J. A. BAILEY, S. JEELANI and S. E. BECKER, *ASME, J. Engng Ind.* **98** (1976) 999.
7. J. A. BAILEY and S. JEELANI, *Wear* **72** (1981) 237.
8. W. P. KOSTER, "Surface Integrity of Machined Materials", USAF Technical Report AFML-TR-74-60 (Metcut Research Associates Inc., Cincinnati, Ohio, 1974).
9. G. BELLOWS and J. B. KOHLS, "Surface Integrity of Non-traditional Material Removal Processes", Technical Paper MRR76-12 (Society of Manufacturing Engineers, Dearborn, Michigan, 1976).
10. S. JEELANI and M. MUSIAL, *Int. J. Fatigue* **6** (1984) 169.
11. S. JEELANI and M. R. COLLINS, *ibid.* **10** (1988) 121.
12. G. BELLOWS, "Low Stress Grinding", Publication No. MDC 83-103 (Machinability Data Center, Cincinnati, Ohio, USA, (1983).
13. J. T. CAMMETT, III., in Proceedings of International Conference on Production Engineering, Tokyo, 1974, Part II (Japan Society of Precision Engineering, Tokyo, 1974) pp. 132-136.
14. D. M. TURLEY and E. D. DOYLE, *Mater. Sci. Engng* **21** (1975) 261.
15. D. M. TURLEY, *Wear* **104** (1985) 323.
16. S. JEELANI, R. NATARAJAN and G. R. REDDY, *Int. J. Fatigue* **8** (1986) 159.
17. D.O.D. Aerospace Structural Metals Handbook, Vol. 4, Code 3706, pp. 1-13. (Mechanical Properties Data Center, Belfour Stulen Inc., Traverne City, Michigan, USA).
18. J. F. KAHLES, M. FIELD, D. EYLON and F. H. FROES, *J. Metals* **37** (1985) 27.
19. M. A. IMAM and D. M. GILMORE, *Met. Trans. (A)* **14A** (1983) 233.
20. G. R. LEVERANT, B. S. LANGER, A. YUEN and S. W. HOPKINS, *ibid.* **10A** (1979) 251.
21. T. TAKEMATO, K. L. JING, T. TSAKALAKOS, S. WEISSMANN and I. R. DRAMER, *ibid.* **14A** (1983) 127.
22. P. RANGASWAMY, MS thesis, Tuskegee Institute (1989).
23. H. TERUTUNG, MS thesis, Tuskegee Institute (1989).

Received 7 February  
and accepted 19 February 1990